



# COMMERCIAL METAL PLANTERS

A DIVISION OF CODE ELECTRIC PRODUCTS LTD.

PRODUCT SPECIFICATION SHEET

01/21/19

## CUBES

**Material:** 0.125" marine grade 5052 aluminum

**Finish:** Durable, UV rated powder coat

**Colour:**

Sterling	Mocha
Slate	Night
Tuscan	Snow

**Drainage Holes:** Yes

**Top Lip:** \* indicates 1" lip

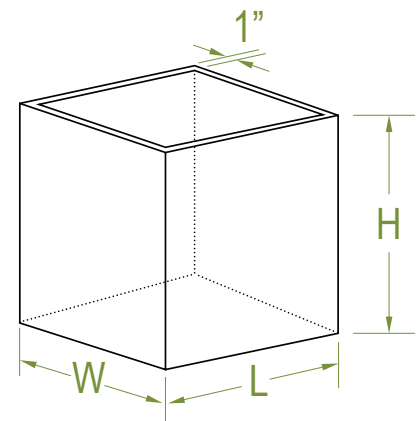
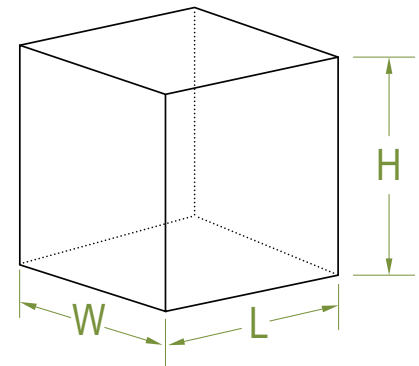
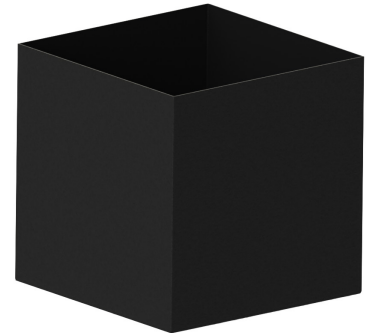

### Dimensions (in):

L	W	H
16	16	16
20	20	20
24	24	24
28	28	28
36	36	36*

### Weights

lbs
12
20
28
48
80

<b>Project:</b>	
<b>Company Name:</b>	
<b>Contact Name:</b>	
<b>Date:</b>	
<b>Approval Signature:</b>	